

I-Series

Industrial Series Compressors



Model FD491



Model WFD591

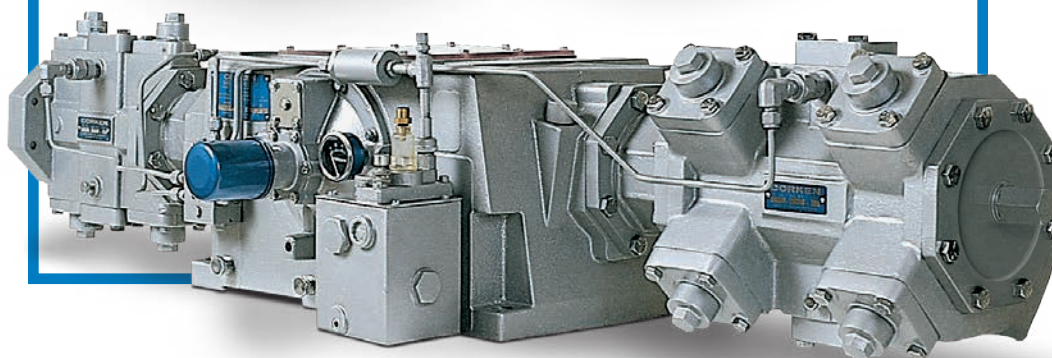

Model HG602

Solutions beyond products...

CORKEN[®]
IDEX

Why Select Corken Compressors?

Oil-free compression for a wide range of process gases...

Corken's line of oil-free industrial series (I-Series) compressors has been designed to transfer a wide range of process gases including, but not limited to, **butadiene, hydrogen, helium, methyl chloride, sulfur dioxide, chlorine** and **HCFCs**. The industrial series compressors are highly reliable reciprocating machines and are used in applications as varied as compressing exotic gases for research, compressing process gases for the chemical industry, compressing corrosive biogases in landfills and boosting gases in the oil and gas industry.

Greater control of fugitive emissions...

For toxic, hazardous and explosive gases, Corken's D-style (single-distance piece with two sets of packing) and T-style (double-distance-piece with three sets of packing) designs provide precise leakage control. When properly equipped, Corken's T-style compressors comply with the EPA's requirements for fugitive emissions control of volatile organic compounds (VOCs).*

Multiple options to match your application requirements...

Corrosion resistant coatings: Corken offers a special coating which acts to prevent corrosion and premature wear of critical parts within the compressor. The coating is a nickel alloy plating which is impregnated with fluorocarbons. See page 11 for details.

Material options: To meet the demands of volatile and toxic gases, Corken offers a wide range of materials for compressor parts, gaskets and O-rings.

ANSI flange option: The industrial series (I-Series) vertical compressors are available with ANSI flanges. ANSI is a raised faced flange that dramatically improves leakage containment and structural integrity. Most of the industrial series (I-Series) horizontal compressors are not available with ANSI flanges; however, they do come with a slip-on weld flange option. The only exception is the 2.75" horizontal cylinder which comes standard with ANSI flanges.

DIN iron option: For maximum thermal shock endurance, Corken offers DIN spec iron for pressure containing parts (cylinder and head) on several of its compressors. These parts meet German DIN ductile iron specifications. Consult factory for details regarding a specific compressor model.

**U.S. Environmental Protection Agency Regulations 40 CFR CH Section 264.1053.*



Model WD391

Compatibility Chart

Air	Carbon tetrachloride	Ethane	Isobutene	Neon	CFC-113	HFC-152A
Ammonia	Carbonyl sulfide	Ethyl chloride	Isobutylene	Nitric oxide	CFC-114	Sulfur dioxide
Argon	Chlorine	Ethylene	Krypton	Nitrous oxide	CFC-115	Sulfur hexafluoride
Benzene	Chlorodifluoro-	Ethylene oxide	Methane	N-octane	CFC500	Tetrafluoroethylene
Biogas	methane	Helium	Methyl acetylene	Ozone	CFC502	Trichloroethane
Butadiene	Cyanogen	Hexafluoroethane	Methyl bromide	N-pentane	CFC503	Trimethylamine
N-butane	Cyclohexane	N-heptane	Methyl chloride	Propane	HCFC-22	Vinyl bromide
1-butene	Cyclopropane	N-hexane	Methyl fluoride	Propylene	HCFC-141B	Vinyl fluoride
Bromotrifluoro-	Deuterium	Hydrocarbon gas	Methyl mercaptan	Refrigerants:	HCFC-142B	Vinyl chloride
methane	Dimethylamine	Hydrogen	Monoethylamine	CFC-11	HFC-14	Xenon
Carbon dioxide	Dimethyl ether	Hydrogen chloride	Monomethylamine	CFC-12	HFC-23	And many more
Carbon monoxide	2,2-dimethylpropane	Isobutane	Natural gas	CFC-13	HFC-134A	

Features & Benefits

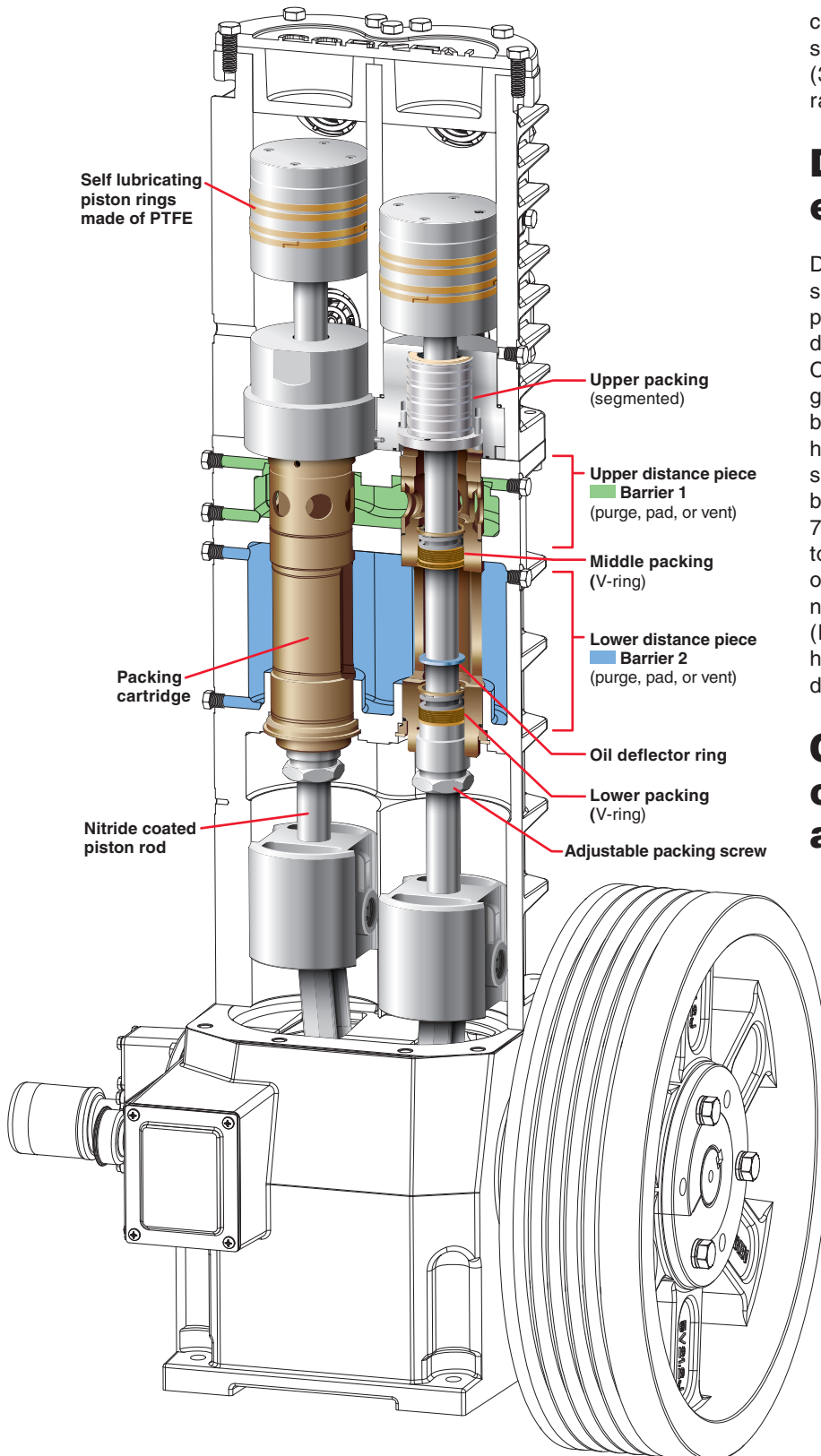

Figure 1: Model T891 single-stage compressor.

compressors come in a variety of single- and two-stage models. Cylinder sizes range from 1.25" to 6" (31.8 to 152.4 mm) while piston displacement ranges from 2.8 to 60.8 CFM (4.76–103.3 m³/hr).

Double-acting designs for even greater capacity...

Double-acting compressors have two compression strokes per revolution so the compression takes place on both sides of the piston. As a result, double-acting compressors offer greater capacities. Corken's model 891 is a double-acting single-stage gas compressor that is capable of supplying between 56.7 and 117.0 CFM (96.3 and 198.8 m³/hr), while the model 791 is a double-acting two-stage compressor with roughly the same capacities but a much higher working pressure. The model 791 has an adjustable clearance head that is used to balance the pressure load between stages. Both of these units are offered in either lubricated or non-lubricated versions. The D791 and D891 (D-style) compressors are not oil-free designs; however, the T791 and T891 (T-style) compressors do offer oil-free gas compression.

Custom engineered compressor packages available...

Corken offers standard mountings designed specifically for liquefied gas transfer, vapor recovery and gas booster applications. If the standard mountings and compressor packages do not meet your application requirements, Corken can supply a custom engineered package that meets the most demanding customer specifications. Skid mounted units can be supplied with control panels, safety controls, pulsation dampeners, receiver tanks, valves and other special accessories as required. For more details see the standard mounting and compressor packages and custom engineered packages at the back of this sales brochure.

**U.S. Environmental Protection Agency Regulations
40 CFR CH Section 264.1053.*

Horizontal Industrial Gas Compressors

Obtain higher pressures and capacities with a horizontal compressor...

When the pressures or capacities of your application are beyond the capabilities of a vertical compressor, the horizontal compressor is your next option. Corken's horizontal industrial compressor is a two-throw design that can build up to 1,650 psig (113 bar g). The available piston displacement ranges from 7.6 CFM (12.9 m³/hr) to 414 CFM (704 m³/hr). This balanced opposed compressor offers smooth, quiet operation and the flexibility of changing cylinder sizes as needed to optimize the compressor for the desired operating conditions. Cylinder sizes are 8" (203.2 mm), 6" (152.4 mm), 5" (127.0 mm), 4" (101.4 mm), 3.25" (82.6 mm), and 2.75" (69.9 mm). These cylinders can be arranged in various single-stage and two-stage configurations. Lubricated, non-lubricated, and oil-free versions are available.

Available in two styles...

Corken offers two styles of horizontal industrial compressors: plain style and T-style. The plain style (HG600 series) only has one set of packing per piston rod while the T-style (THG600 series) has three sets of packing per piston rod.

Use a single-packed, plain style for standard leakage containment...

The plain style (HG600 series) horizontal industrial compressor is not oil free and only has one set of packing. This packing configuration is typically used in non-corrosive, non-toxic services where oil-free gas is not required and leakage containment is not critical. Some examples are LPG, oilfield applications (natural gas) and air boosting applications.

Use a triple-packed, T-style for maximum leakage containment...

The T-style (THG600 series) is a non-lubricated, oil-free design with three sets of packing that form two distance pieces or

barriers to external leakage (see figure 2 for details). For a wide range of application flexibility, each distance piece has its own line connections that can be pressurized, purged or vented separately. This allows you to choose the best method of containment for your application. When properly equipped with a purge kit, Corken's double-distance piece (T-style) provides precise leakage control and complies with the EPA's requirements for fugitive emissions control of volatile organic compounds (VOC).^{*} For added convenience, purge kits with all of the accessories needed to control the purging or pressurization of each chamber are available. T-styles are typically used in corrosive or toxic applications where leakage containment and non-contamination of the gas stream are critical.

Piston rod packing design...

Unlike Corken's vertical industrial compressor that uses a V-ring packing design, the horizontal industrial compressor uses a segmented purge packing design. Segmented purge packing consists of purge packing cups, spacers, O-rings, segmented packing, backup rings and springs.

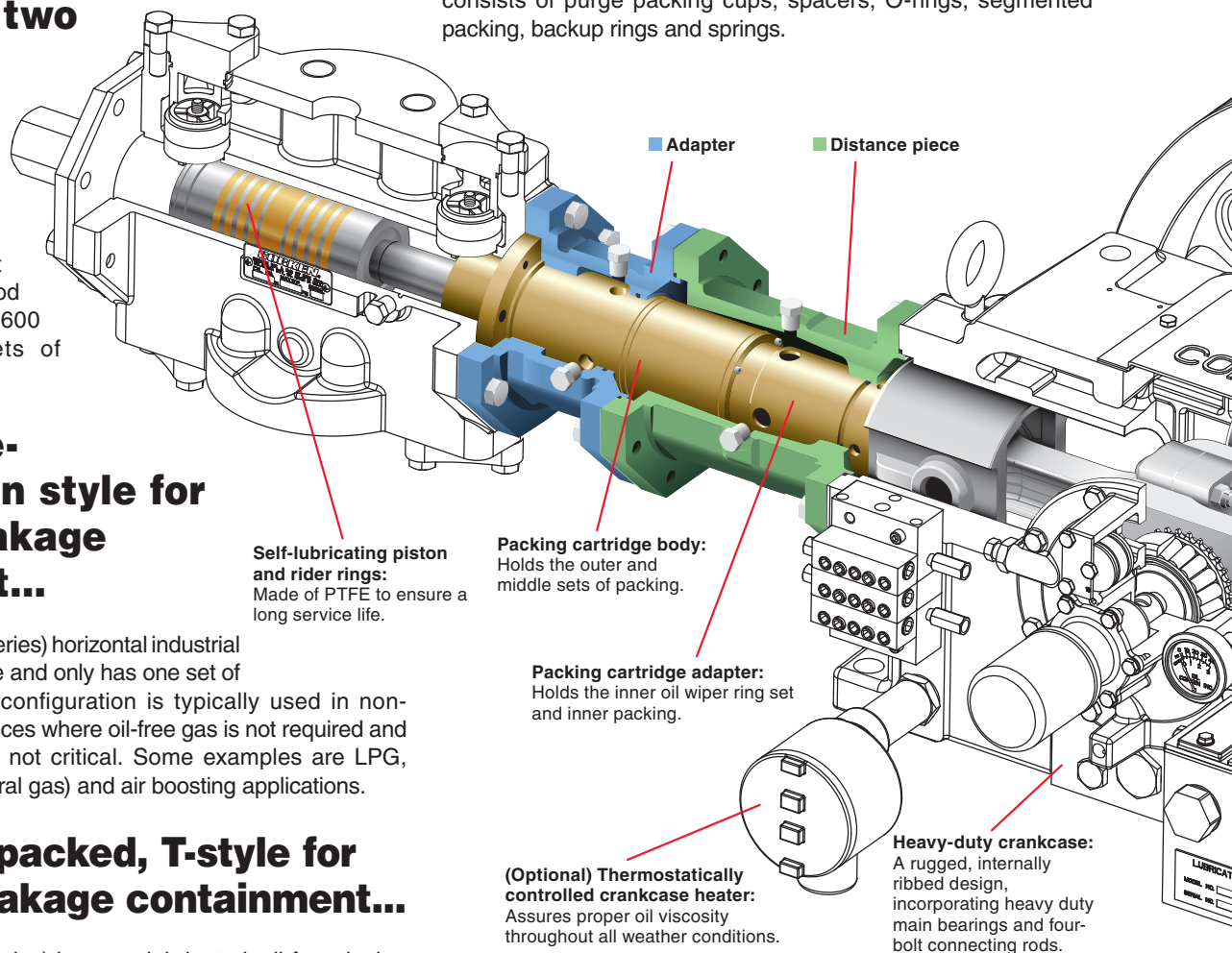

Figure 2: THG602BF (T-style) compressor.

Features & Benefits

Oil-free gas compression...

To meet the stringent requirements of today's markets, Corken's T-style (double-distance piece) horizontal compressors are oil free so there's no contamination of the process gas stream. The T-style has three sets of segmented packing. Since the distance between each set of packing is greater than the stroke of the compressor, there's no rod over travel or oil carryover. In other words, the portion of the piston rod that comes into contact with the first set of packing will never reach the second set of packing while the portion of the piston rod that comes into contact with the second set of packing will never reach the third set of packing. In the event oil gets past the inner packing set, the oil deflector ring keeps the oil from reaching the outer distance piece (see figure 2 for details).

Available in single- or double-acting configurations...

The plain and T-style horizontal industrial compressors are available in single- or double-acting configurations. Single-acting configurations are ideal for applications that require low flow and high pressure while

double-acting configurations offer maximum capacity. Single-acting configurations require a blank valve option.

External crankcase oil cooler...

Corken's horizontal industrial compressors are equipped with a force-feed-lubrication system and external oil filter. For applications that require a high horsepower, Corken recommends an optional external oil cooler. This will ensure a consistent oil temperature and an optimal service life for the compressor.

Custom engineered compressor packages available...

Corken offers standard mountings designed specifically for liquefied gas transfer, vapor recovery and gas booster applications. If the standard mountings and compressor packages do not meet your application requirements, Corken can supply a custom engineered package that meets the most demanding customer specifications. Skid mounted units can be supplied with control panels, safety controls, pulsation dampeners, receiver tanks, valves and other special accessories as required. For more details see the standard mounting and compressor packages and custom engineered packages at the back of this sales brochure.

**U.S. Environmental Protection Agency Regulations 40 CFR CH Section 264.1053.*

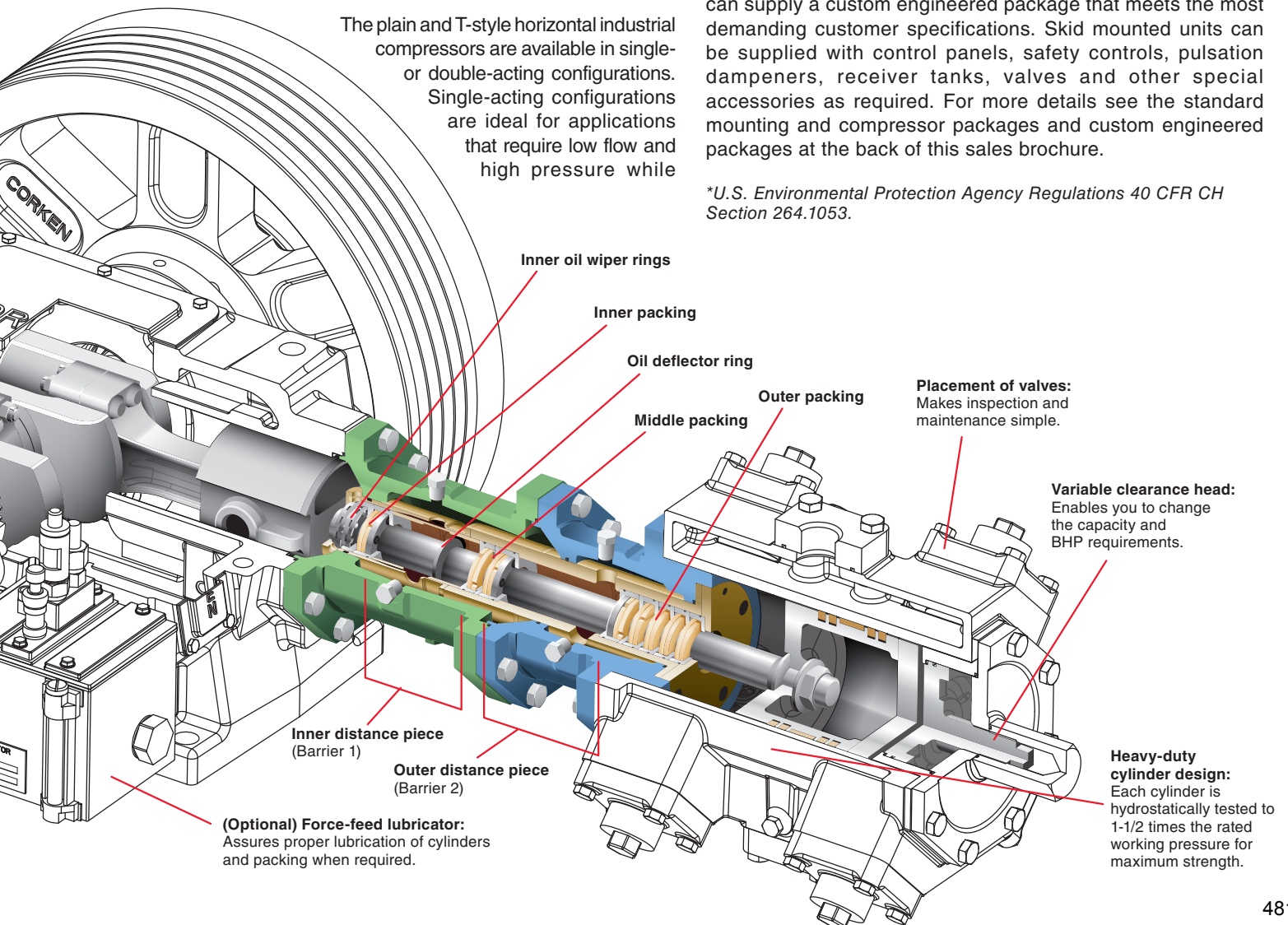

Vertical Industrial Gas Compressors

Compressors matched to your needs...

Corken offers many types of vertical industrial compressors to meet the stringent requirements of today's markets. Depending on your application, Corken can provide single- or two-stage, air- or water-cooled, and single- and double-acting vertical compressors. Lubricated and non-lubricated versions are available as well.

Water-cooled heads, cylinders and packing...

To increase the versatility of the vertical industrial compressors used in the process gas market, Corken offers water-cooled heads, cylinders and packing on several models. The water-cooled features greatly reduces the operating temperature and allows the compressor to be used in applications with gases that have a high K value such as argon, air, helium, hydrogen, and nitrogen.

Oil-free gas compression...

Corken's vertical industrial compressors deliver oil-free gas compression and are equipped with a single-distance piece (D-style) or a double-distance piece (T-style). The D-style has two sets of packing per piston rod while the T-style has three sets of packing per piston rod. Since the distance between each set of packing is greater than the stroke of the compressor, there's no rod over travel or oil carryover. In the event oil gets past the lower packing set, the oil deflector ring keeps the oil from rising up the piston rod (see figure 1 for details). Additionally, the lower packing set has an adjustable packing screw that is used to maintain maximum sealing performance. These features allow the compressor to supply oil-free gas whether it's being used as a simple gas booster or for vacuum service. Both single- and two-stage compressors are capable of developing up to 23 in Hg (157 mm Hg) vacuum.

Piston rod packing design...

With the exception of models 791 and 891, all of Corken's vertical industrial compressors use a V-ring packing design. Models 791 and 891 use a combination of V-ring and segmented packing. V-ring packing consists of several V-rings, male and female packing rings, washers and a spring. In high temperature applications, K-ring spacers (optional) can be used in conjunction with the V-ring packing to improve leakage control and help extend the

service life of the packing. Segmented packing consists of packing cups, spacers, O-rings, segmented packing, backup rings and a spring.

Greater leakage control and containment...

The D-style (single-distance piece) forms one isolation chamber while the T-style (double-distance piece) forms two isolation chambers/barriers (see figure 1 for details). Each distance piece has its own line connections and can be separately pressurized, purged or vented depending on the requirements of your application. Purge kits with all of the accessories needed to purge each distance piece are available. With the purge kit option, the T-style compressor is virtually leak proof and complies with the EPA requirements for fugitive emissions control of volatile organic compounds (VOC).*

Single-stage oil-free compressors...

Corken's single-stage compressors are typically used in applications where the gas compression ratio is less than 5:1. Generally, applications with relatively low differential pressures are well suited for a single-stage compressor. Transport, rail car and marine unloading by vapor differential are examples of this type of application.

Two-stage oil-free compressors...

Corken's two-stage compressors are typically used in applications where the gas compression ratio is greater than 5:1. The two-stage compressors divide the compression process into two separate steps and allow the gas to be cooled after the first stage of compression so the final discharge temperature is lower. These compressors are commonly used in booster and vapor recovery applications. Due to the need for higher differential pressures which result in higher operating temperatures, Corken also offers a water-cooled, two-stage compressor where both the cylinder and the head are cooled.

Single-acting designs with a wide range of capacities...

Single-acting vertical compressors only have one compression stroke per revolution so the compression takes place on one side (top) of the piston. The single-acting

Vertical Industrial Gas Compressors

Operating Specifications

Specifications		Single-Stage Compressors						Two-Stage Compressors							
D-style (single-distance piece)		D91	D291	D491	D491-3	D691	D691-4	D891 ^a	FD151	D191	FD351	D391	WFD551	FD591	D791 ^a
T-style (double-distance piece)		T91	T291	T491	T491-3	T691	T691-4	T891 ^a	FT151	T191	FT351	T391	WFT551	FT591	T791 ^a
Bore of cylinder inches (mm)															
First stage		3.0 (76.2)	3.0 (76.2)	4.0 (101.6)	3.0 (76.2)	4.5 (114.3)	4.0 (101.6)	4.5 (114.3)	2.5 (63.5)	3.0 (76.2)	2.75 (69.9)	4.5 (114.3)	4.0 (101.6)	6.0 (152.4)	6.0 (152.4)
Second stage								3.0 (76.2)	1.25 (31.8)	1.75 (44.5)	1.75 (44.5)	2.5 (63.5)	2.5 (63.5)	3.25 (82.5)	3.25 (82.5)
Stroke inches (mm)		2.5 (63.5)	2.5 (63.5)	3.0 (76.2)	3.0 (76.2)	4.0 (101.6)	4.0 (101.6)	4.0 (101.6)	2.5 (63.5)	2.5 (63.5)	3.0 (76.2)	3.0 (76.2)	4 (101.6)	4.0 (101.6)	4.0 (101.6)
Piston displacement CFM (m ³ /hr)	@ 400 rpm	4.1 (7.0)	8.2 (13.9)	17.5 (29.7)	9.8 (16.7)	29.5 (50.1)	23.3 (39.6)	56.7 (96.3)	2.8 (4.76)	4.1 (7.0)	4.1 (7.0)	11.1 (18.9)	11.6 (19.7)	26.2 (44.5)	52.4 (89.0)
	@ 825 rpm	8.4 (14.3)	16.9 (28.7)	36.0 (61.2)	20.3 (34.5)	60.8 (103.3)	48.0 (81.6)	117.0 (198.8)	5.9 (10.0)	8.9 (15.2)	8.5 (14.4)	22.8 (38.7)	24.8 (42.1)	54.0 (91.7)	105.8 (179.8)
Maximum working pressure psig (bar g)		335 (23.1)	335 (23.1)	335 (23.1)	600 (41.4)	335 (23.1)	600 (41.4)	450 (31.0)	1,200 (82.8)	600 (41.4)	1,200 (82.8)	600 (41.4)	1,000 (69.0)	600 (41.4)	600 (41.4)
Maximum brake horsepower (kW)		7.5 (5.6)	15 (11)	15 (11)	15 (11)	35 (26.1)	35 (26.1)	45 (34)	15 (11)	15 (11)	15 (11)	15 (11)	35 (26.1)	35 (26.1)	45 (34)
Maximum rod load lbs (kg)		3,600 (1,633)	3,600 (1,633)	4,000 (1,814)	4,000 (1,814)	7,000 (3,175)	7,000 (3,175)	7,000 (3,175)	3,600 (1,633)	3,600 (1,633)	4,000 (1,814)	4,000 (1,814)	7,000 (3,175)	7,000 (3,175)	7,000 (3,175)
Maximum discharge temperature °F (°C) ^b		350 (177)	350 (177)	350 (177)	350 (177)	350 (177)	350 (177)	350 (177)	350 (177)	350 (177)	350 (177)	350 (177)	350 (177)	350 (177)	350 (177)
Bare unit weight with flywheel lbs (kg)		150 (68.0)	210 (95.2)	390 (176.9)	390 (176.9)	745 (337.9)	745 (337.9)	900 (408.2)	215 (97.5)	215 (97.5)	340 (154)	350 (158.8)	815 (369.7)	790 (358.8)	930 (421.9)
ANSI/DIN flange option		Yes	Yes	Yes	Yes	Yes	Yes	–	Standard	Yes	Standard	Yes	Standard	Standard	–
Water-cooled option		–	–	–	–	Yes	Yes	–	–	–	Yes	Yes	Standard	Yes	–

^aDouble-acting compressor

^b350°F discharge temperature requires use of high temperature O-rings, such as PTFE or Viton. Maximum recommended discharge temperature for use with Buna N or Neoprene O-rings is 250°F.

Note: Specific application conditions may limit a compressor's operating performance to less than the values shown on this page. Contact a Corken distributor or the factory for verification. Specifications may be changed without liability or advance notice.

Selection Criteria for Vertical and Horizontal Compressors

Corken's vertical industrial gas compressors offer piston displacement ranging from 2.8 to 117 CFM (4.76 to 198.8 m³/hr) while horizontal gas compressors offer piston displacement ranging from 7.6 to 414 CFM (12.9 to 704 m³/hr). Sizing and selection of a gas compressor requires many pieces of information. Corken applications engineers and sales staff have the skills to properly size and select the best machine to meet your needs.

When applying Corken gas compressors, please provide the engineer the following information:

- Gas name (give % composition if a mixture)
- Gas characteristics if not common (material compatibility, toxicity, EPA regulated, etc.)

- Gas data if not common (critical temperature, critical pressure, specific gravity, molecular weight)
- Ambient temperatures
- Ambient pressure if above or below sea level
- Gas suction pressure (specify psia or psig, bar a or bar g and if the compressor will pull a vacuum)
- Gas suction temperature
- Gas discharge pressure and any temperature limitations
- Desired flow rate in ACFM, lbs/hr, SCFM, Actual m³/hr, kg/hr, or Standard m³/hr
- Description of the application

With this information, our engineers will size the compressor and select materials and options that suit the gas and your particular application. A computer printout of your performance data is also provided with the quotation.

Horizontal Industrial Gas Compressors

Operating Specifications

Single-Stage Horizontal Compressors

Single Cylinder Models	HG601AX THG601AX	HG601BX THG601BX	HG601CX THG601CX	HG601DX THG601DX	HG601EX THG601EX	HG601FX THG601FX
Size	8"	6"	5"	4"	3.25"	2.75"
Displacement cfm (m ³ /hr)						
400 rpm	68.8 (116.9)	38.4 (65.2)	26.4 (44.9)	16.8 (28.5)	10.8 (18.3)	7.6 (12.9)
1200 rpm	207.0 (351.7)	115.0 (195.4)	79.2 (134.4)	49.8 (84.6)	32.2 (54.5)	22.8 (56.0)
Approximate shipping weight lb. (kg.)						
HG model	730 (331.1)	650 (295.0)	640 (290.3)	630 (285.8)	620 (281.2)	620 (281.2)
THG model	780 (353.8)	700 (317.5)	690 (313.0)	680 (308.4)	670 (303.9)	670 (303.9)
Two Cylinder Models	HG601AA THG601AA	HG601BB THG601BB	HG601CC THG601CC	HG601DD THG601DD	HG601EE THG601EE	HG601FF THG601FF
Size	8" x 8"	6" x 6"	5" x 5"	4" x 4"	3.25" x 3.25"	2.75" x 2.75"
Displacement cfm (m ³ /hr)						
400 rpm	138 (234.5)	76.8 (130.5)	52.8 (89.7)	33.2 (56.4)	21.2 (36.0)	14.8 (25.1)
1200 rpm	414 (704)	231 (393)	158.4 (268.8)	99.6 (169.2)	64 (108.7)	44.4 (75.6)
Approximate shipping weight lb. (kg.)						
HG model	1,070 (485.4)	910 (412.8)	890 (403.7)	870 (394.6)	845 (383.3)	845 (383.3)
THG model	1,170 (530.7)	1,010 (458.1)	990 (449.1)	970 (440.0)	945 (428.7)	945 (428.7)

Two-Stage Horizontal Compressors

Two Cylinder Models	HG602AB THG602AB	HG602AC THG602AC	HG602AD THG602AD	HG602BC THG602BC	HG602BD THG602BD	HG602BF THG602BF
Size	8" x 6"	8" x 5"	8" x 4"	6" x 5"	6" x 4"	6" x 2.75"
Displacement cfm (m ³ /hr)						
400 rpm	68.8 (116.9)	68.8 (116.9)	68.8 (116.9)	38.4 (65.2)	38.4 (65.2)	38.4 (65.2)
1200 rpm	207.0 (351.7)	207.0 (351.7)	207.0 (351.7)	115.0 (195.4)	115.0 (195.4)	115.0 (195.4)
Approximate shipping weight lb. (kg.)						
HG model	990 (449.1)	980 (444.5)	970 (440.0)	930 (421.9)	895 (406.0)	880 (399.2)
THG model	1,090 (494.4)	1,080 (489.9)	1,070 (485.4)	1,030 (467.2)	995 (451.3)	980 (444.5)
Two Cylinder Models (continued)	HG602BE THG602BE	HG602CD THG602CD	HG602CF THG602CF	HG602DE THG602DE	HG602DF THG602DF	HG602EF THG602EF
Size	6" x 3.25"	5" x 4"	5" x 2.75"	4" x 3.25"	4" x 2.75"	3.25" x 2.75"
Displacement cfm (m ³ /hr)						
400 rpm	38.4 (65.2)	26.4 (44.9)	26.4 (44.9)	16.8 (28.5)	16.8 (28.5)	10.8 (18.3)
1200 rpm	79.2 (134.4)	79.2 (134.4)	79.2 (134.4)	49.8 (84.6)	49.8 (84.6)	32.2 (54.5)
Approximate shipping weight lb. (kg.)						
HG model	880 (399.2)	880 (399.2)	867 (393.3)	860 (390.1)	860 (390.1)	845 (383.3)
THG model	980 (444.5)	980 (444.5)	967 (438.6)	960 (435.5)	960 (435.5)	945 (428.7)

Cylinder Data

Description	Cylinder Code					
	A	B	C	D	E	F
Cylinder bore in. (mm)	8 (203.2)	6 (152.4)	5 (127)	4 (101.6)	3.25 (82.6)	2.75 (69.9)
Maximum working pressure psig (bar g)	300.0 (20.7)	350 (24.1)	750 (51.7)	1,000.0 (69.0)	1,200.0 (82.8)	1,650.0 (113.8)

Frame Data

Stroke inches (mm)	3.0 (76.2)
Maximum gas rod load lb (kg)	7,000 (3,175.2)
Maximum motor size hp (kW)	75 (55.9)
Maximum discharge temp °F (°C) ^a	350.0 (176.7)
Minimum temp °F (°C)	-25 (-31.6)
RPM range	400 - 1,200

^a350°F discharge temperature requires use of high temperature O-rings, such as PTFE or Viton. Maximum recommended discharge temperature for use with Buna N or Neoprene O-rings is 250°F.

Vertical & Horizontal Compressor Options

Corken offers many options and accessories...

Purge Kit Accessories: Due to new regulations and the growing number of gases that pose possible safety and environmental hazards, leakage containment and control has become a high priority. For maximum leakage control, Corken offers purge kits for D- and T-style industrial compressors. The purge kits have all of the accessories needed to purge or pressurize each distance piece. For a wide range of application flexibility, each distance piece has its own line connections and can be separately pressurized, purged or vented. This flexibility allows you to choose the best method of containment for your application. Figure 3 illustrates how a typical purge kit operates on a T-style (triple packing with double-distance piece) vertical industrial compressor.

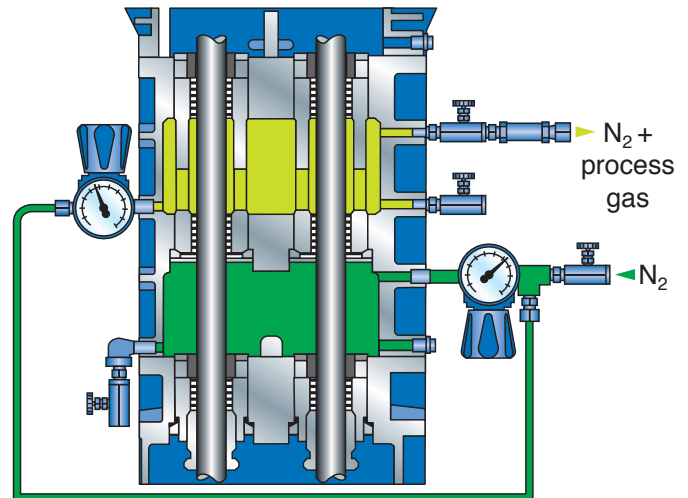

Figure 3: A vertical T-Style (double-distance piece) compressor is shown above with the purge kit option. Purge kits are used to pressurize or purge the distance piece.



Crosshead guide, piston rod, packing barrel, K-ring spacers and packing set.

K-ring Spacers: These spacers, when used in conjunction with our V-ring packing, offer improved leakage control and extend service life in applications where operating temperatures exceed 250°F (121°C).

Liquid Traps: Corken offers automatic electric and mechanical traps. The automatic electric design incorporates one or two liquid level switches depending on specific requirements. Custom traps are available on package units. Traps constructed per ASME code are optional. See figure 4 for details.

Safety and Control Switches: Corken can supply safety shutdown switches for pressure, temperature, liquid level and vibration to meet international and U.S. specifications. These switches, in conjunction with a control panel, can effectively automate the operation of the compressor.

Intercoolers/Aftercoolers: Corken offers water-cooled and air-cooled intercoolers/aftercoolers in a variety of materials. Custom designed heat exchangers are available for applications which require extra cooling or special material considerations.

Piston Rod Coating Options: To minimize piston rod wear and increase corrosion resistance, Corken recommends the Nitrotec^{®1} coating for most applications. Nitrotec^{®1} piston rods are made from specially heat treated steel having a dark gray finish and is a standard option on all industrial compressors. If the Nitrotec^{®1} coating does not meet your needs, an optional coating is available.

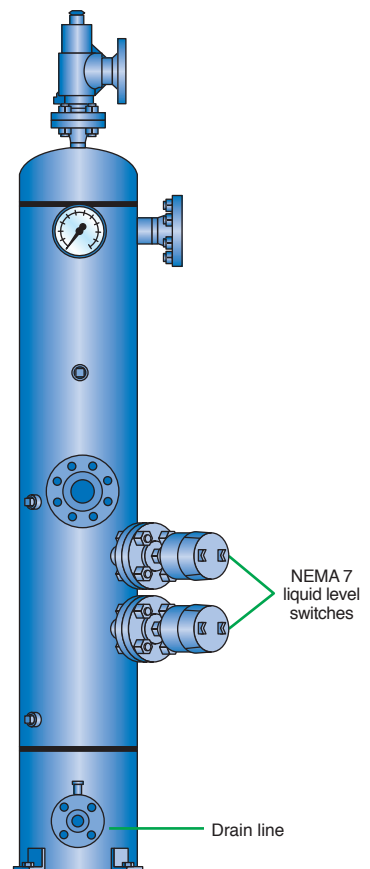

Figure 4: Flanged, ASME code liquid trap with liquid-level switches, manual drain and stainless steel demister pad.

Vertical & Horizontal Compressor Options

MC1002 Coating: This coating significantly increases component life in corrosive gas service. It will not peel or chip and offers increased corrosion, moisture, abrasion and chemical resistance. Lab tests indicate that piston rings can last up to three times longer when used with an MC1002-coated cylinder.

Suction Valve Unloaders: Unloaders may be used to provide loadless starting and/or constant speed unloading. Loadless starting is required in applications which have a high initial differential pressure. Constant speed unloading allows for loading and unloading the compressor while it is running rather than stopping and starting the compressor in order to control capacity.

ALLOY 50 piston rings and rod packing: ALLOY 50 (a proprietary composition) is recommended when compressing a very dry gas with a high K value. These gases tend to have high operating temperatures and offer minimal lubricating qualities. ALLOY 50 material extends the service life of the piston rings and rod packing and minimizes leakage.

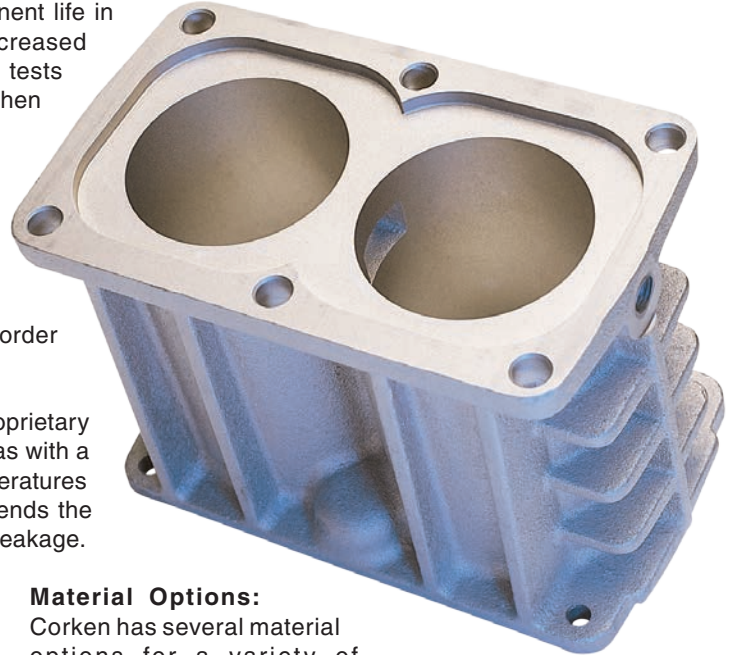

MC1002 coated cylinder.



ALLOY 50 piston rings and V-ring piston rod packing.

Material Options:

Corken has several material options for a variety of compressor parts. Piston rings are available in ALLOY 50, PEEK and other filled PTFE, blends. Valve plates are available in stainless steel and PEEK materials. Optional materials for piston rods are also available. O-rings are offered in PTFE, Viton^{®2}, Buna-N or Neoprene^{®2}. Consult the factory for optional materials that can be specified on special applications.

Options to match your process gases...

Corken offers numerous options that adapt to your compression needs. The table on the following page lists some of the more common gases and some of the hazards associated with these gases. As noted, certain gases or gas mixtures are corrosive, flammable, explosive or toxic. Many of these factors will affect the selection of the compressor and accompanying options. Some of the more common options are matched up with the assorted gases listed on the following page; however, this not a comprehensive list of required options. Based on years of experience, Corken's sales engineers will recommend the most suitable materials of construction and select the appropriate options based on your application and product. These engineers carefully review your specifications and recommend the components necessary for the optimal performance of the selected compressor. As part of Corken's continuous improvement program, new state-of-the-art materials are continually being evaluated to enhance the compressor life in gas applications.

¹Registered trademark of TTI Group, Ltd.

²Registered trademark of the DuPont Company.

Solutions beyond products...

CORKEN[®]

Matching Options with Process Gases



Explosive



Flammable



Corrosive



Toxic



T-style

Double-Distance Piece

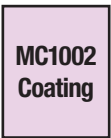

MC1002 Coating

Corrosion Resistant Coating



Alloy 50

Piston Rings & Rod Packing Materials

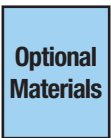

Optional Materials

Optional Materials

Type of Gas	Formula					T Style	MC 1002 Coating	Alloy 50	Optional Materials	Comments
Amines									●	Copper, aluminum and zinc prohibited. PTFE O-rings and iron/lead trim recommended.
Ammonia	NH ₃			●	●				●	Copper and copper alloys prohibited.
Argon	AR					●		●		Leak tightness important. Compression ratios are limited due to high specific heat ratio.
Biogas		●	●	●	●		●		●	Highly corrosive when wet. Recommendations will vary depending on nature of mixture.
Butadiene	C ₄ H ₆	●	●		●	●			●	Copper and copper alloys prohibited. Leak tightness is important.
Butane, butene	C ₄ H ₁₀ / C ₄ H ₈	●	●							Easily liquefied.
CFC, HFC, HCFC						●		●	●	Leak tightness important.
Carbon dioxide	CO ₂			●			●			Acidic when wet, compression ratios are limited due to high specific heat ratios.
Carbon monoxide	CO	●			●					No high nickel alloys or pure nickel. Compression ratios are limited due to high specific heat ratio.
Chlorine	Cl ₂			●	●	●	●		●	Highly corrosive when wet, chrome oxide piston rod coating and PTFE O-rings required.
Dimethylamine	(CH ₃) ₂ NH	●	●		●	●			●	Copper, tin, zinc prohibited. PTFE O-rings required.
Dimethyl ether	(CH ₃) ₂ O	●	●						●	Optional O-ring material available.
Ethane	C ₂ H ₆	●	●							
Ethylene	C ₂ H ₄	●	●							Iron/lead trim and PTFE O-rings recommended.
Ethylene oxide	C ₂ H ₄ O	●	●		●	●	●		●	Copper, silver, magnesium prohibited. PTFE O-rings required.
Helium	He					●		●	●	Leak tightness important. Compression ratios are limited due to high specific heat ratio.
Hydrocarbon gases	HC	●	●							Unusual compressibility factors, chance of liquefaction.
Hydrogen	H ₂	●	●			●		●	●	Leak tightness very important. Compression ratios are limited due to high specific heat ratio.
Hydrogen chloride	HCl			●	●	●	●		●	Chrome oxide piston rod coating recommended. Iron/lead trim and PTFE O-rings required. Compression ratios are limited due to high specific heat ratio.
Isobutane	CH(CH ₃) ₃	●	●							
Isobutylene	(CH ₃) ₂ C:CH ₂	●	●						●	Iron/lead trim and PTFE O-rings required.
Methane	CH ₄	●	●							
Methyl chloride	CH ₃ Cl	●	●	●	●	●	●		●	Zinc, aluminum, magnesium, and their alloys prohibited. Chrome oxide piston rod coating recommended. PTFE O-rings recommended.
Methyl mercaptan	CH ₃ SH	●	●		●	●	●		●	Copper, lead, zinc prohibited. PTFE O-rings required.
Natural gas		●	●							Review composition of mixture.
Nitrogen	N ₂							●		Usually very dry with no lubricating qualities. Compression ratios are limited due to high specific heat ratio.
Nitrous oxide	N ₂ O			●			●		●	Avoid any hydrocarbons.
Propylene	C ₃ H ₆	●	●			●			●	Leak tightness important. Iron/lead trim and PTFE O-rings recommended.
Sulfur Dioxide	SO ₂			●	●	●	●		●	Corrosive when wet. Leak tightness important.
Vinyl chloride	CH ₂ CHCl	●	●			●	●		●	Chrome oxide piston rod coating recommended. Iron/lead trim and PTFE recommended.

Note: Consult factory for selection of appropriate options.

Standard Compressor Packages

I-Series compressors are used in many applications...

- Air boosting
- Gas blanketing
- Instrumentation
- Landfill gas recovery
- Liquid transfer
- Pressure boosting
- PSA gas generation
- Refrigerant reclaiming
- Selective catalytic reduction
- Tank car unloading
- Vapor recovery

Industries served...

Process

- Chemical / petrochemical processing

Energy

- Oil & natural gas production
- Alternative fuel
- Liquefied gases
- Electric power generation

Transportation

- Truck & transport
- Liquid & liquefied gas terminals
- Marine

Corken offers three standard mountings for our industrial compressors. The 103 mounting is a basic mounting and allows for maximum flexibility for on-site installation. The 107 is designed with a 4-way valve and liquid trap to be used in LTVR (liquid transfer vapor recovery) operations. The 109 mounting has a liquid trap for use in liquefied gas service but no 4-way valve, and is best suited when vapor recovery is not needed.

The various 107 and 109 mountings are available with three different liquid trap configurations. The first liquid trap, used on the 107 and 109, is a mechanical liquid trap that uses a floating ball to block the suction and cut off flow before liquid can enter and damage the compressor. The 107A and 109A have an automatic liquid trap that uses a single NEMA 7 liquid level switch for shut down control. The 107B and 109B use a larger ASME code liquid trap with two NEMA 7 liquid level switches that are used for alarm and shut down, or can be configured to operate a dump system.

All have the option of the heavy-duty mounting which is often employed for slow running operations to balance out the rotational forces. Add an HD (heavy duty) to the end of any standard mounting number to make it heavy duty and be sure to add the heavy-duty flywheel as well.

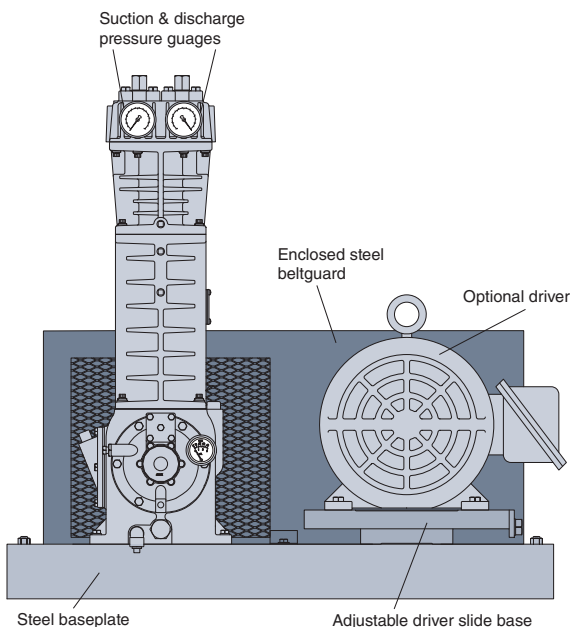

-103 mounting shown above.

103 Mounting

- Steel baseplate
- V-belt drive
- Adjustable driver slide base
- Enclosed steel beltguard
- Suction and discharge pressure gauges

Standard Compressor Packages (continued)

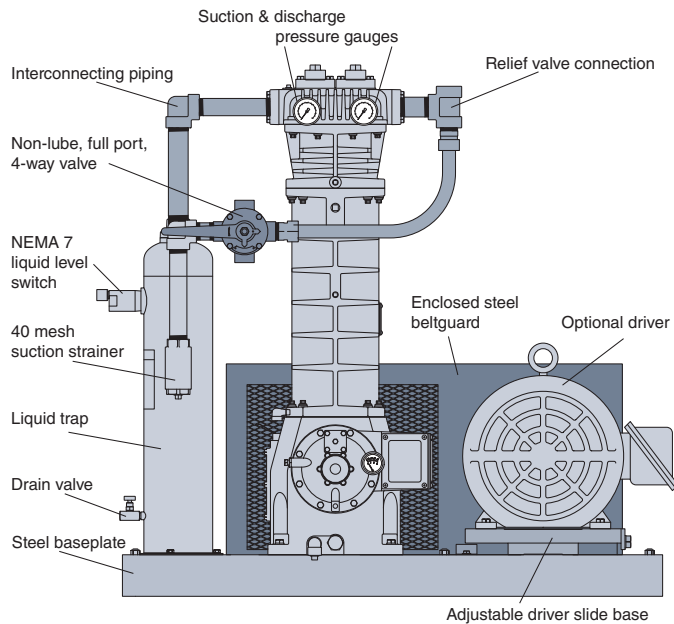

-107A mounting shown above.

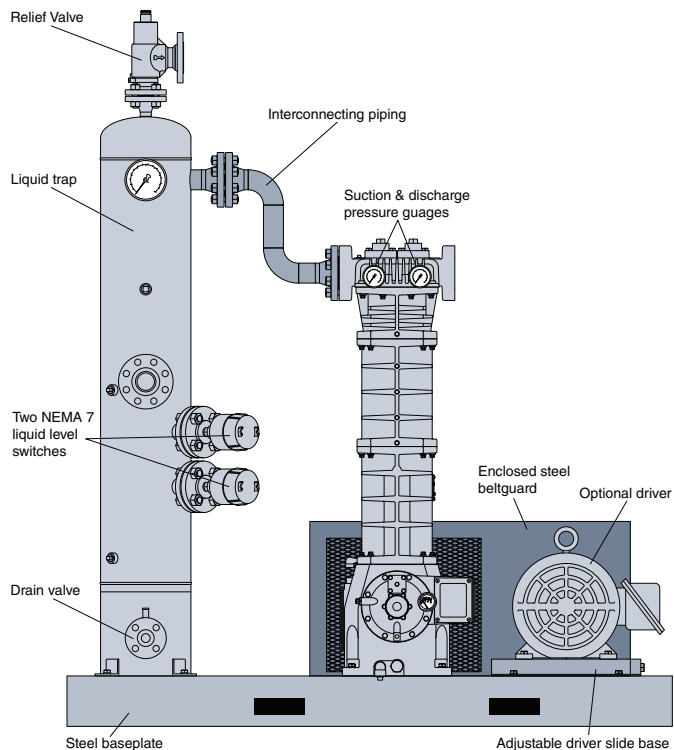

-109F mounting shown above.

Standard 107 Items

- All 103 items plus
- 40 Micron strainer
- Non-lube 4-way valve
- Interconnecting piping
- Liquid trap as specified below

107 Mounting

- Mechanical liquid trap with ball float

107A Mounting

- Automatic liquid trap with one NEMA 7 liquid level switch

107B Mounting

- Automatic liquid trap with two NEMA 7 liquid level switches

107F Mounting

- 107A or 107B with 300# ANSI flanged components and connections

Standard 109 Items

- All 103 items plus
- Interconnecting piping
- Liquid trap as specified below

109 Mounting

- Mechanical liquid trap with ball float

109A Mounting

- Automatic liquid trap with one NEMA 7 liquid level switch

109B Mounting

- Automatic liquid trap with two NEMA 7 liquid level switches

109F Mounting

- 109A or 109B with 300# ANSI flanged components and connections

Custom Engineered Compressor Packages

When you cannot fit one of Corken's standard mountings into your application, we will customize one for you. Most custom packages are a modification of our standard mountings; however, if your needs do not fit within one of our custom packages, we can start from scratch and build you a mounting or skid from the floor up. Send in your specifications and one of our application engineers will design a custom engineered package to meet your needs.



Above: D891-109F single-stage compressor package designed for a liquefied gas transfer application using vinyl chloride.

Right: HG602CE-109C two-stage compressor package designed for LPG sphere evacuation. This package can operate in single-stage and two-stage mode for deep evacuation. This package can also be used for propylene and other products.

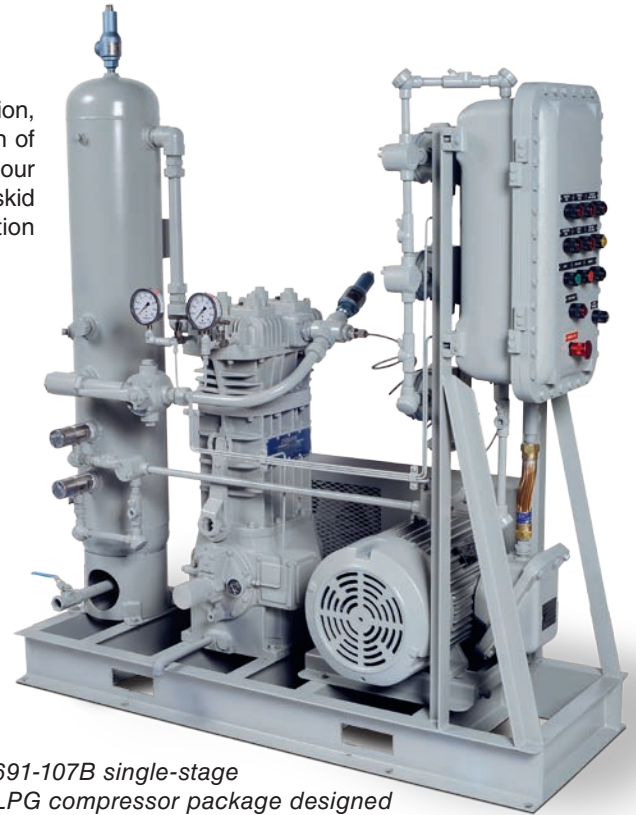

691-107B single-stage LPG compressor package designed for liquefied gas transfer and vapor recovery applications.



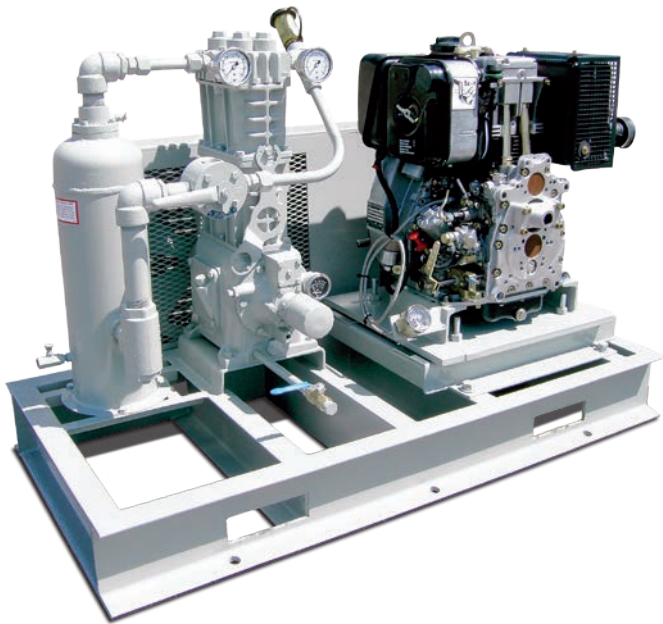

291-107 single-stage compressor package designed for tank maintenance evacuation and emergency evacuation situations like an over turned tank car or transport truck.



FT691-107B single-stage compressor package designed for liquefied gas transfer and vapor recovery applications.



FT491-109F single-stage, flanged compressor package designed for liquefied gas transfer applications using vinyl chloride, butadiene and methyl chloride.

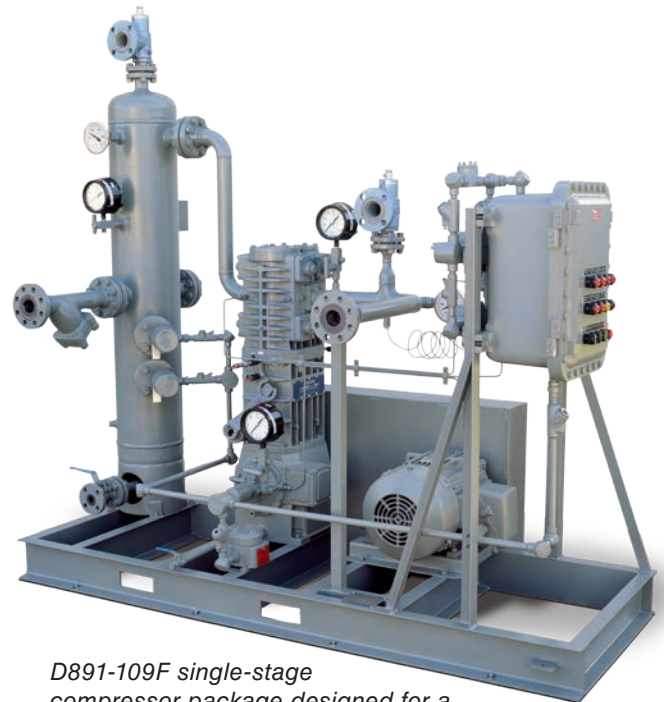

D891-109F single-stage compressor package designed for a liquefied gas transfer application using propylene.

Solutions beyond products...

CORKEN
IDEX